

# General Purpose Clutches

## FS20 and 50

Indexing, Backstopping External Bearing Support Required, Sprag Clutches



Series 20 and 50 clutches provide all the outstanding features of the Formsprag design for backstop applications with the exception that the customer supplies his own inner race, and provides the concentricity between the races.

This assembly is particularly advantageous on such applications as gear reducers where the backstop can be incorporated into a bearing bore and an extension of an existing shaft can be used for an inner race.

The outer surface of this clutch is basically the same as the outer surface of a standard bearing. The tolerance on the outer diameter is held to insure a proper fit (without pressing) into a continuation of the bore which accommodates the adjacent bearing. The tolerance on this bore should follow the bearing manufacturer's recommendation for the bearing used. Taper within this bore should not exceed .0002 inch per inch.

FS 20 and 50 clutches are oil dipped at the factory *but must be filled to the proper level before operation.*

The model FS 50 can not be used with lubricants that contain EP additives, see page 132. The model FS 20 has a special sprag design that will work with all types of lubricants including those with EP additives.

### Specifications

Size	Torque Capacity lb.in. (Nm)	Overrunning Speed (Inner Race only) Max. RPM		Shipping Weight lb. (kg)
		Grease* Oil-Mist or Spray	Pressure Lubrication or Oil Bath	
FS-20-3	468 (52.8)	2,500	2,500	0.5 (.22)
FS-20-4	600 (67.8)	2,500	2,500	0.75 (.34)
FS-20-5	960 (108.48)	2,500	2,500	0.75 (.34)
FS-20-6	2100 (237.3)	2,000	2,000	1.0 (.45)
FS-20-7	3300 (372.9)	2,000	2,000	1.25 (.56)
FS-20-8	4860 (549.18)	1,800	1,800	1.75 (.80)
FS-20-10	6900 (779.7)	1,800	1,800	2.0 (.91)
FS-50-9A	3,000 (339)	1,800	2,000	1.62 (.736)
FS-50-11A	6,300 (724)	1,800	2,000	2.60 (1.182)
FS-50-12A	8,000 (904)	1,800	2,000	3.03 (1.377)
FS-50-13	15,000 (1725)	1,200	1,750	6.20 (2.818)

\* Overrunning speeds are reduced 50% from listed values for grease lubrication.

### Typical Mounting Arrangements

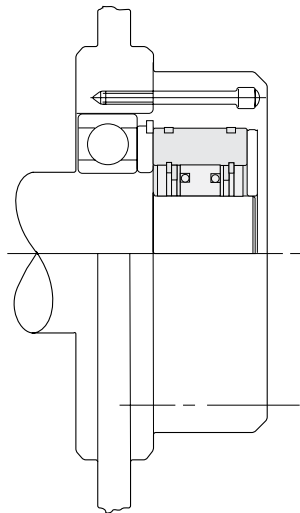

Series 20 and 50 clutch mounted inside the bearing retainer cap

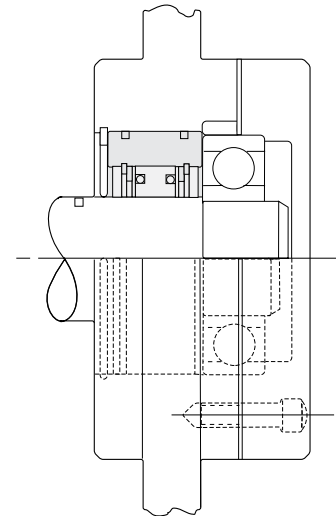

Series 20 and 50 clutch mounted directly in the housing bore

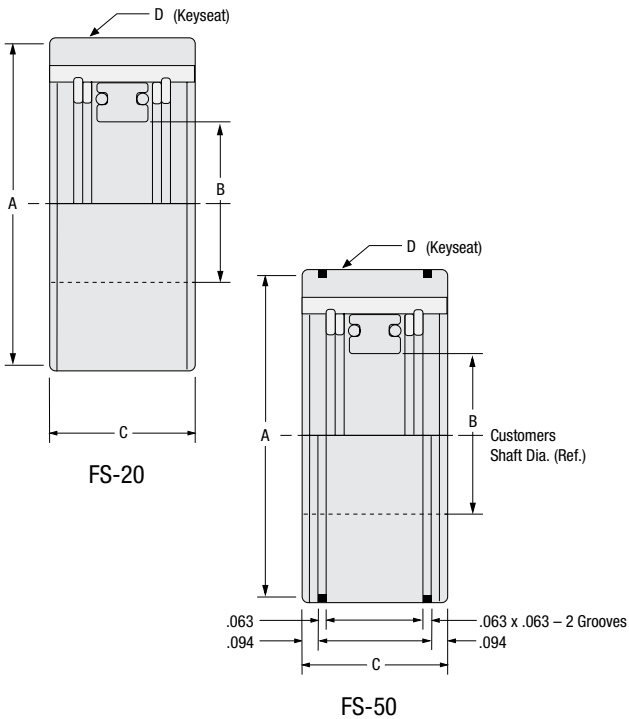

### Dimensions inches (mm)

Size	Standard Bearing Sizes O.D. Dia.	A	B	C	D
FS-20-3	203	1.5743/1.5728 (39.99/39.95)	0.650/0.649 (16.51/16.49)	1.0 (25.4)	1/8 x 1/16 (3.48 x 1.57)
FS-20-4	204	1.8498/1.8483 (46.98/46.95)	0.740/0.739 (18.80/18.77)	1.0 (25.4)	3/16 x 3/32 (4.75 x 2.36)
FS-20-5	205	2.0463/2.0448 (51.98/51.94)	0.930/0.929 (23.62/23.60)	1.0 (25.4)	3/16 x 3/32 (4.75 x 2.36)
FS-20-6	206	2.4403/2.4388 (61.98/61.95)	1.290/1.289 (32.77/32.74)	1.125 (28.58)	1/4 x 1/8 (6.35 x 3.18)
FS-20-7	207	2.8341/2.8326 (71.99/71.95)	1.657/1.656 (42.09/42.06)	1.125 (28.58)	1/4 x 1/8 (6.35 x 3.18)
FS-20-8	208	3.1491/3.1476 (79.99/79.95)	1.841/1.840 (46.76/46.74)	1.25 (31.75)	3/8 x 3/16 (9.52 x 4.75)
FS-20-10	210	3.5428/3.5413 (89.99/89.95)	2.209/2.208 (56.11/56.08)	1.25 (31.75)	3/8 x 3/16 (9.52 x 4.75)
FS-50-9A	207	2.8332/2.8322 (71.96/71.94)	1.1335/1.1325 (28.79/28.77)	1.25 (31.75)	.250 x .13 (6.35 x 3.30)
FS-50-11A	3L10	3.149/3.148 (79.98/79.96)	1.378/1.377 (35.00/34.98)	1.63 (41.40)	.375 x .19 (9.53 x 4.83)
FS-50-12A	3L11	3.542/3.541 (89.97/89.94)	1.541/1.540 (39.14/39.12)	1.63 (41.40)	.375 x .19 (9.53 x 4.83)
FS-50-13	XLS-3.25	4.750/4.749 (120.65/120.62)	2.0457/2.0447 (51.96/51.94)	1.75 (44.45)	.500 x .25 (12.7 x 6.35)

**Note:** Series 50 clutches are intended primarily for use as built-in backstops in reducers.

### Housing Tolerance

The recommended tolerance on the housing bore to assure proper clutch fit for the Model FS-20 clutches are listed in the following chart.

Sizes	Tolerance of housing bore
203 to 210	0 to +.001 (0 to +0.025 mm) TIR*

### Concentricity

The concentricity between the inner race (shaft) sprag diameter and backstop bore in the housing is critical. It can be measured as shown, with the base of the indicator mounted on the end of the shaft. The shaft end should be square with the sprag diameter.

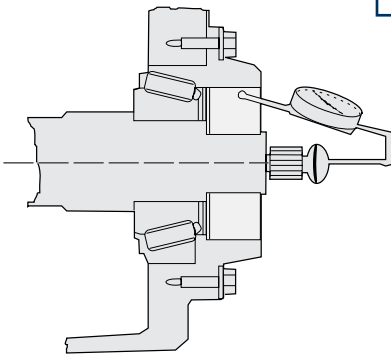

The concentricity requirements are listed below:

FS-50-9A, 11A, 12A	.003 TIR*
FS-50-13	.004 TIR*
FS-203-210	.002

\* Total Indicator Reading

**Note:** No snap ring grooves in sizes 203, 205, 206, 207, 208 or 210.

### WARNING

*Installation of a backstop into a system without the proper concentricity, shaft hardness requirements and lubrication can result in the unexpected back driving or slipping of the clutch. Carefully read and follow the instructions provided with the clutch assembly and the instructions provided by the original equipment manufacturer prior to installing the clutch. Failure to observe these precautions could result in bodily injury.*

### Shaft Requirements

The shaft extension which serves as the inner race should be carburized to a depth of .050 inches to .060 inches after grinding and hardened to Rockwell 58-62 "C". Taper on this shaft should also not exceed .0002 per inch. The core hardness should be 28-40 Rockwell "C". The microfinish should be 15-25 RMS.

### Lubrication

If possible, backstops should be mounted below the oil level.

The oil level should not be below the inner race (shaft).

**Note:** If backstop is mounted above the oil level, positive means such as spray or pressure lubrication should be provided to ensure adequate lubrication.

For grease lubrication the overrunning speeds are reduced 50% from listed values.